

TUFTED HEADBOARD

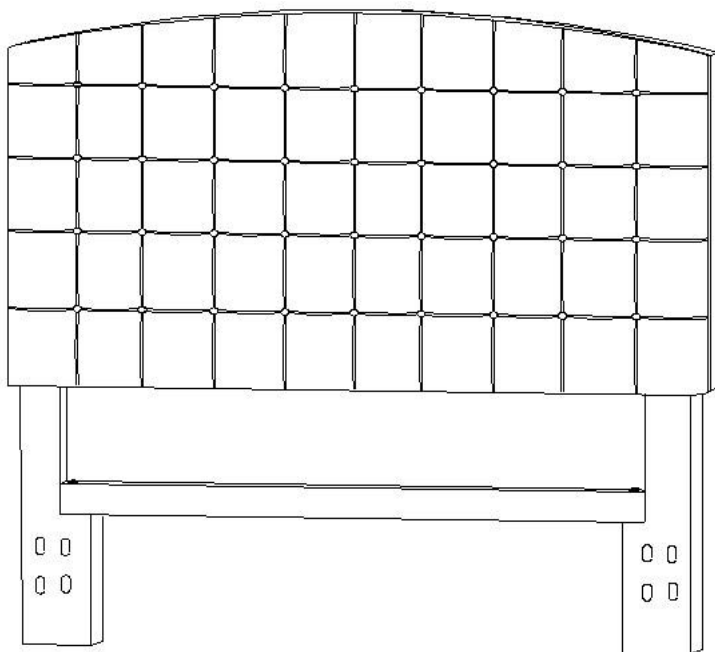

Model No:
WM4015H-FQ

UPC CODE:
0-65857-16020-8

NOTE:
THIS INSTRUCTION BOOKLET
CONTAINS **IMPORTANT** SAFETY
INFORMATION. PLEASE READ AND
KEEP FOR FUTURE REFERENCE.

Lot number:
(TAKEN FROM CARTON)

Date of purchase:

____ / ____ / ____

DO NOT RETURN PRODUCT TO THE STORE.
If a part is missing or damaged, contact our customer service
department. We will replace the part **FREE** of charge.



Tel #: 1-800-295-1980
E-Mail: das@dorel.com
Fax #: 514-353-7819

CUSTOMER SERVICE

If you are missing parts or have any questions about this product, contact our customer service representative first!

 **CALL 1-800-295-1980**

You can also order parts by writing to the address listed below. Please include the product model number, color and a detailed description of the part.

**Customer Service Department No. 413
12345 Albert-Hudon Boulevard, Suite 100
Montreal, Quebec
Canada H1G 3L1**

E-MAIL: das@dorel.com

NOTES

- * Ensure all parts and components are present before beginning assembly.
- * Assembly and handling will require two people.
- * Assemble on a soft, smooth surface to prevent damage to the product finish.
- * Read all instructions completely before assembly.
- * **DO NOT** use power tools.
- * **CAUTION:** Adult assembly required.
- * Estimated assembly time: 15 minutes.
- * The bed frame is not included and must be purchased separately.

CARE AND CLEANING

Dust regularly with a soft, dry cloth to prevent soil build-up. Wipe away spills immediately to prevent staining. Use a cloth dampened with water or a professional product to clean the fabric. Always test an inconspicuous area first. Allow upholstery to dry and brush lightly. Keep away from heat to avoid glazing, melting or scorching.

MAINTENANCE

Check bolts/screws periodically and tighten them if necessary.

LIMITED WARRANTY

Dorel Asia warrants its product to be free from defects in material and workmanship and agrees to remedy any such defect. This warranty covers 1 year from the date of original purchase. This warranty is valid only upon presentation of proof of purchase. This is solely limited to the repair or replacement of defective furniture components and no assembly labor is included. This warranty does not apply to any product which has been improperly assembled, subjected to misuse or abuse or which has been altered or repaired in any way. Any wearing, tearing, fading or splitting of the leather is not covered under the warranty. This warranty gives you specific legal rights and you may also have other rights which vary from State to State.







WARNING: Should this product become damaged, and/or components are broken or missing, DO NOT USE.

TUFTED HEADBOARD

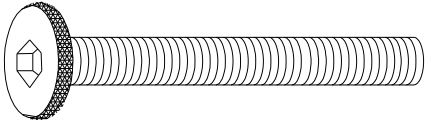
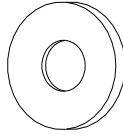
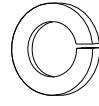
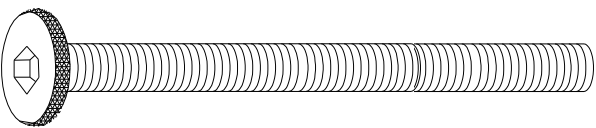
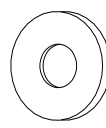
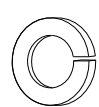
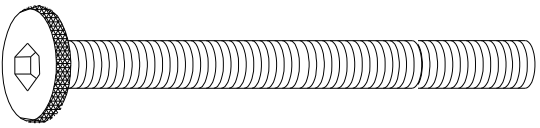
WM4015H-FQ

HARDWARE LIST

<p>1</p>  <p>Ø5/16" X 50mm</p>	<p>2</p>  <p>Ø22*1.8mm</p>	<p>3</p>  <p>Ø12.5*1.2mm</p>
<p>HEX SOCKET HEAD BOLT</p> <p>8 PCS</p>	<p>FLAT WASHER</p> <p>16 PCS</p>	<p>SPRING WASHER</p> <p>12 PCS</p>
<p>4</p>  <p>Ø1/4" X 90mm</p>	<p>5</p>  <p>Ø16*1.8mm</p>	<p>6</p>  <p>Ø10.5*1.2mm</p>
<p>HEX SOCKET HEAD BOLT</p> <p>2 PCS</p>	<p>FLAT WASHER</p> <p>2 PCS</p>	<p>SPRING WASHER</p> <p>2 PCS</p>
<p>7</p>  <p>Ø5/16" X 63mm</p>	<p>8</p>  <p>Ø8mm</p>	<p>9</p>  <p>Ø4mm</p>
<p>HEX SOCKET HEAD BOLT</p> <p>4 PCS</p>	<p>NUT</p> <p>4 PCS</p>	<p>ALLEN KEY</p> <p>1 PC</p>
<p>10</p>  <p>Ø5mm</p>	<p>11</p> 	
<p>ALLEN KEY</p> <p>1 PC</p>	<p>WRENCH</p> <p>1 PC</p>	

TUFTED HEADBOARD

WM4015H-FQ

PARTS LIST

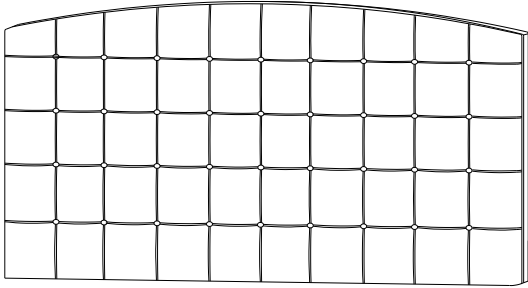
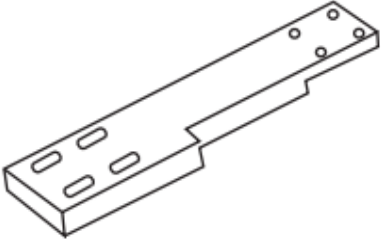
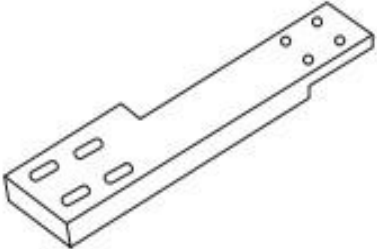
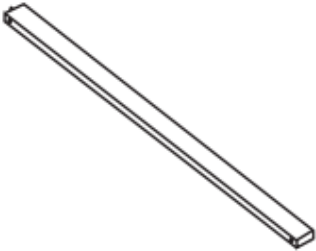
A		B	
HEADBOARD 1 PC		LEFT LEG 1 PC	
C		D	
RIGHT LEG 1 PC		STRETCHER 1 PC	

NOTE: LEGS (B & C) AND STRETCHER (D) ARE PACKED INSIDE THE HEADBOARD (A). PULL BACK THE FABRIC LINING BEHIND THE HEADBOARD TO COLLECT ALL PARTS.

TUFTED HEADBOARD WM4015H-FQ

STEP 1:

Insert stretcher (D) into the left leg (B) and right leg (C) and secure using flat washers (5), spring washers (6) and hex socket head bolts (4).

Use Allen Key (9) to tighten the bolts.

Note: Do not over tighten the bolts.

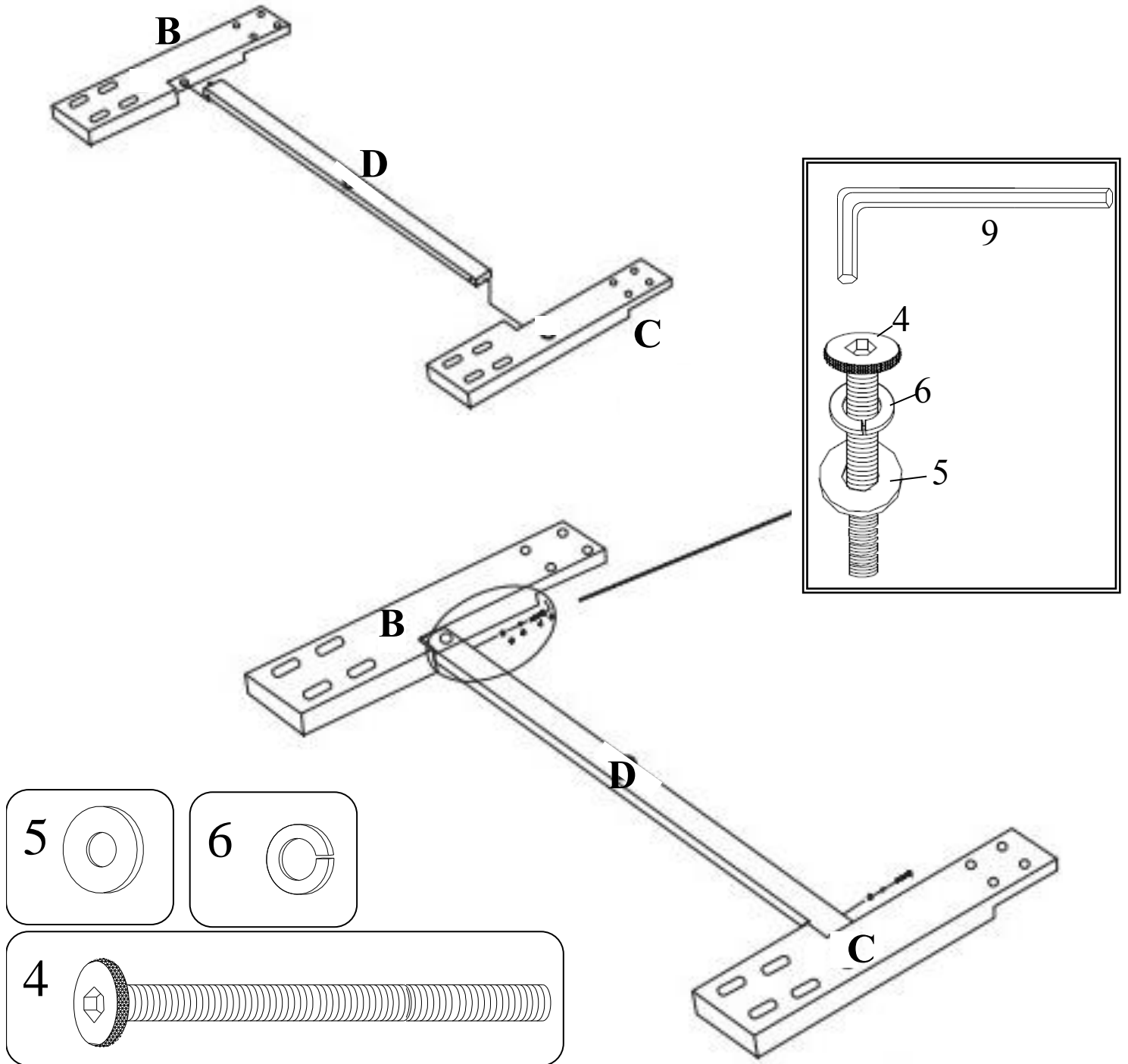

TUFTED HEADBOARD

WM4015H-FQ

STEP 2:

Pull back the fabric lining on the back of the headboard (A).

Attach the assembled legs to the headboard (A) using flat washers (2), spring washers (3) and hex socket head bolts (1).

Use Allen Key (10) to tighten the bolts.

Place the fabric lining back into place.

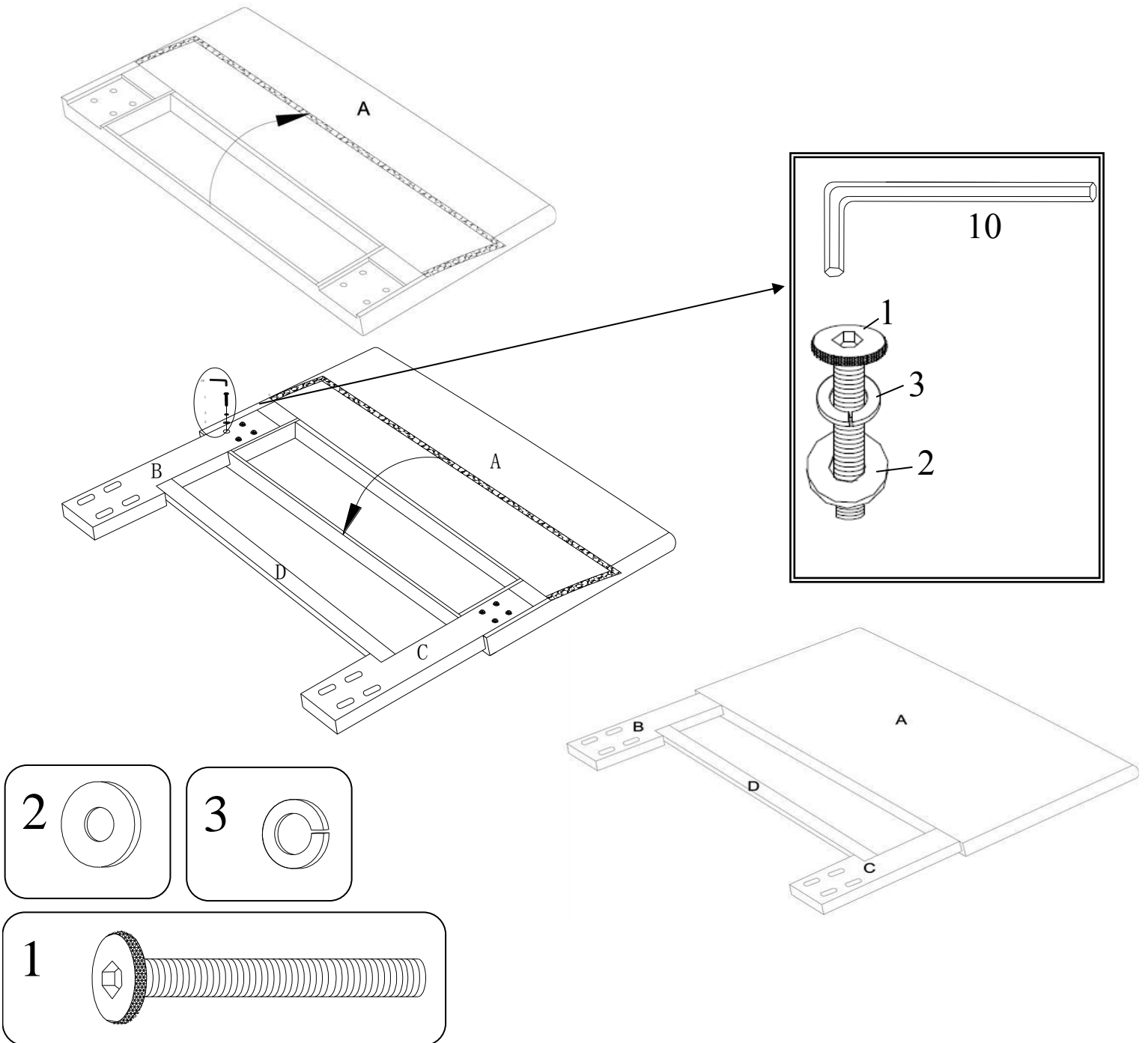

TUFTED HEADBOARD WM4015H-FQ

NOTE: THE BED FRAME IS NOT INCLUDED AND MUST BE PURCHASED SEPARATELY. THE FOLLOWING ILLUSTRATIONS ARE FOR REFERENCE ONLY.

Attach the bed frame (purchased separately) to bed posts using bolts (7), spring washers (3), flat washers (2) and nuts (8). Use Allen Key (10) to tighten bolts and use the open end wrench (11) to tighten the nuts (8).

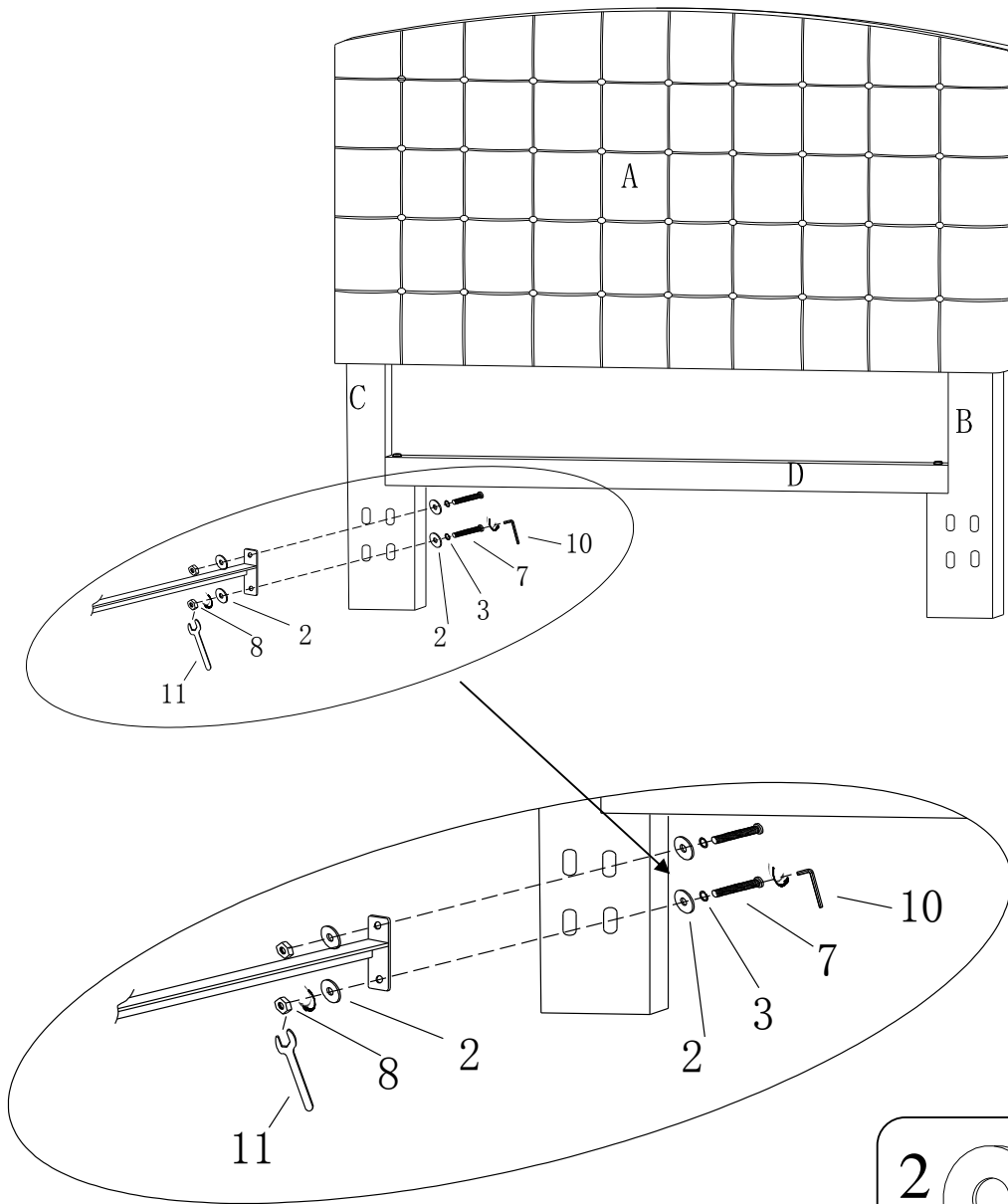

For a Queen Size Bed,
attach the bed frame to the
outer holes.

For a Full Size Bed,
attach the bed frame to the
inner holes.

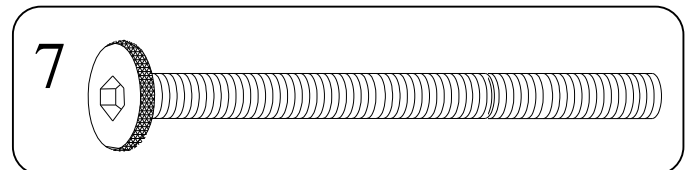
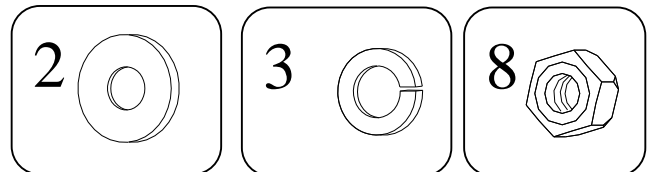

TUFTED HEADBOARD

WM4015H-FQ



CAUTION: This unit is intended for use only with the products and/or maximum weights indicated. Use with other products and/or products heavier than the maximum weights indicated may result in instability or cause possible injury.

Dust regularly with a soft, dry cloth to prevent soil build-up.

Wipe away spills immediately to prevent staining. Use a cloth dampened with water or a professional product to clean the fabric.

Always test an inconspicuous area first. Allow upholstery to dry and brush lightly. Keep away from heat to avoid glazing, melting or scorching.

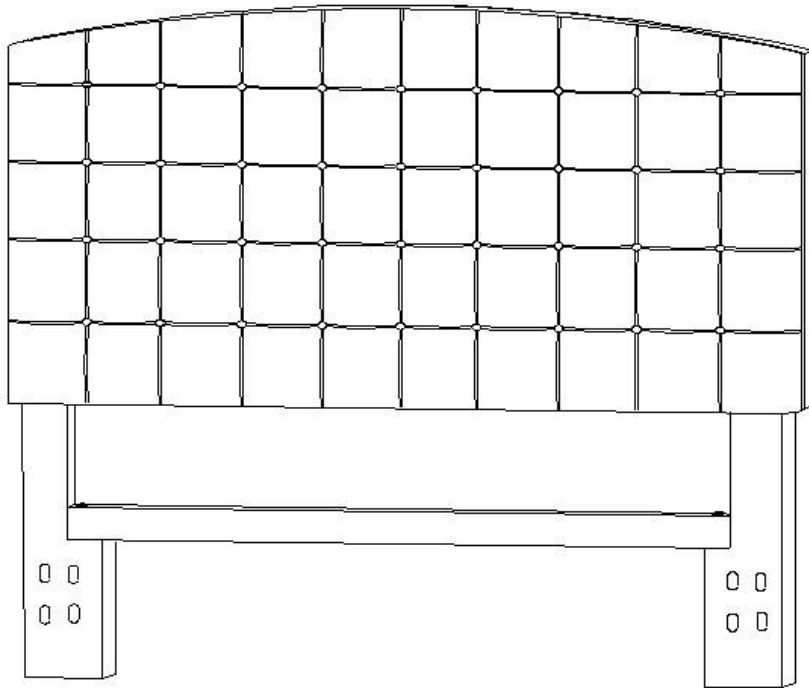

That's it! You've finished assembling your headboard.

DO NOT RETURN PRODUCT TO THE STORE.

If a part is missing or damaged, contact our customer service department. We will replace the part **FREE** of charge.



Tel #: 1-800-295-1980
E-Mail: das@dorel.com
Fax #: 514-353-7819

Customer Service

PLEASE DO NOT RETURN THIS PRODUCT TO THE STORE

PLEASE CONTACT CUSTOMER SERVICE REPRESENTATIVES AT THE FOLLOWING NUMBERS SHOULD THERE BE ANY MISSING OR DEFECTIVE PART(S).

Customer Service Phone Number 1-800-295-1980	Email: das@dorel.com
Customer Service Fax Number 514-353-7819	

Request Date:

Name:

Shipping Address:

Street & Number:

City & State:

Zip Code:

Day Time Phone Number:

(including area code)

Date & Place of Purchase:

Part(s) description and quantity (Please be sure to list model number or SKN number):